



# DANOBAT

## VERTICAL GRINDING AND MEASURING

---

### VG

### VG VERTICAL GRINDING AND MEASURING

DANOBAT VG high precision cylindrical vertical grinding machine range has been designed to suit specific applications of our customers.

The finest technologies are utilized to achieve the highest rigidity and precision. These machines have been designed on a modular basis to meet each customer's needs ranging from universal configuration machines to the most demanding customizations. This modularity provides flexibility to achieve the shortest lead time and optimum cost for a machine made to order.



## VG TECHNICAL DESCRIPTION

TECHNICAL CHARACTERISTICS		VG-600	VG-800	VG-1000	VG-1500	VG-2000
Grinding diameter (max.)	mm	600	800	1000	1500	2000
Grinding height (max.)	mm	400	600	500/700/1000	500/1000/1500	500/1000
Table load	kg	1200	1200	2000	3000	4000
Máx. C axis speed	rpm	200	200	150	100	100

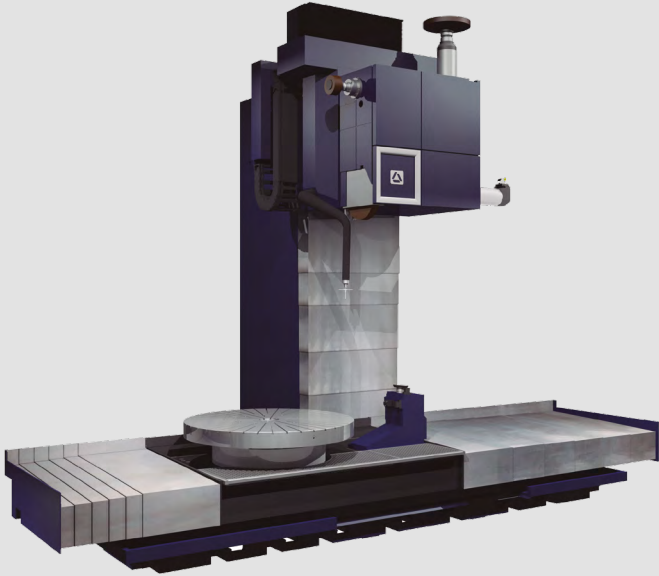

- Natural granite bed on VG-600 / 800
- Stabilized pearlitic cast iron bed on VG-1000 / 1500 / 2000
- Main elements of the machine made of stabilized pearlitic cast iron.
- Independent slides for vertical and traverse movements.
- Linear guideways with recirculating linear roller bearings on VG-1000 / 1500 / 2000
- External linear scales on all machine axes.
- Swivelling B Axis with integrated torque motor.
- Precision radial and axial hydrostatic bearing on C Axis.

### VG optional equipment

- Part measuring system.
- Swivel slide (B Axis) (Hirth coupling / continuous positioning).
- Fully enclosed machine inox. guarding.
- T-Slotted table top or pallet system.
- Dressing spindle.
- Deburring system (brush type or high pressure coolant).
- Automatic Tool Changer.
- Scanner measuring system.
- Touch probe measuring system.
- Wheel balancing systems.
- Tool presetting system.
- External set up station and pallet clamping system.
- Turning arm.
- Magnetic table.
- Chip conveyor.
- Mist extractor.

## LPT DISC



## HPC ROTOR SHAFT



## STUB SHAFT



## STATOR CASE

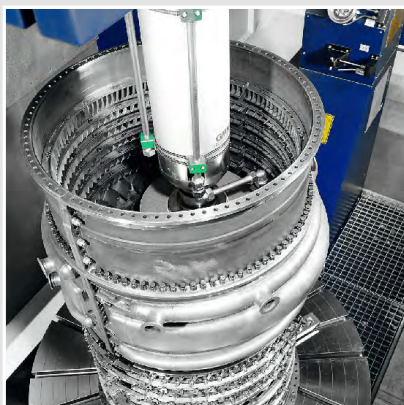

## GEAR

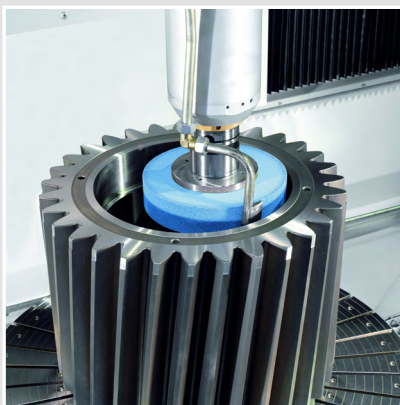

## IPC ROTOR



## BEARING

